

Features

- Supply Voltage 5V (Typically)
- Very Low Power Consumption: 150 mW (Typically) for -1 dBm Output Level
- Very Good Sideband Suppression by Means of Duty Cycle Regeneration of the LO Input Signal
- Phase Control Loop for Precise 90° Phase Shifting
- Power-down Mode
- Low LO Input Level: -10 dBm (Typically)
- 50-Ω Single-ended LO and RF Port
- LO Frequency from 100 MHz to 1 GHz
- SO16 Package

Benefits

- No External Components Required for Phase Shifting
- Adjustment Free, Hence Saves Manufacturing Time
- Only Three External Components Necessary, this Results in Cost and Board Space Saving

Electrostatic sensitive device.

Observe precautions for handling.



1. Description

The U2790B is a 1000-MHz quadrature modulator using Atmel®'s advanced UHF process. It features a frequency range from 100 MHz up to 1000 MHz, low current consumption, and single-ended RF and LO ports. Adjustment-free application makes the direct converter suitable for all digital radio systems up to 1000 MHz, e.g., GSM, ADC, JDC.

Figure 1-1. Block Diagram

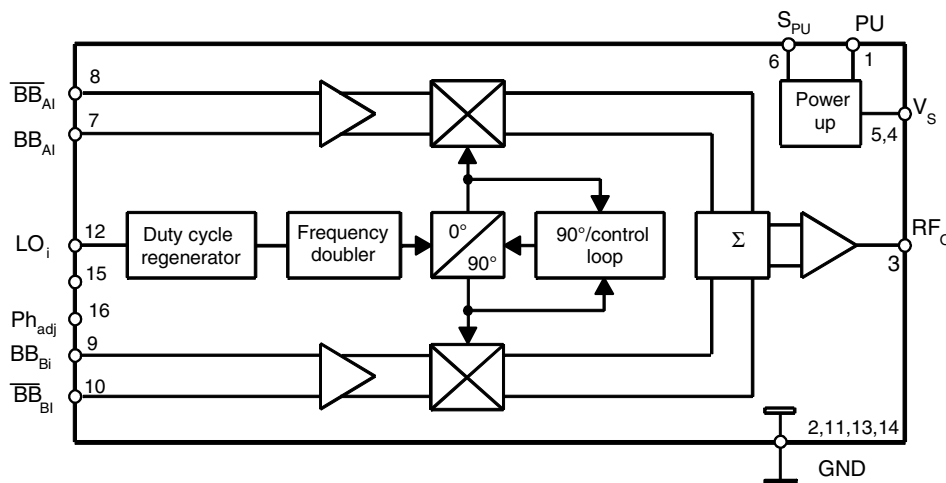

1000-MHz Quadrature Modulator

U2790B

2. Pin Configuration

Figure 2-1. Pinning SO16

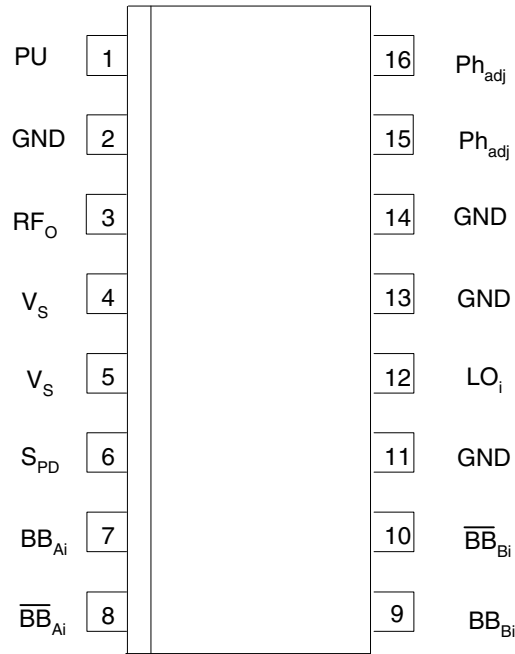

Table 2-1. Pin Description

Pin	Symbol	Function
1	PU	Power-up input
2, 11, 13, 14	GND	Ground
3	RF _O	RF output
4, 5	V _S	Supply voltage
6	S _{PU}	Settling time power-up
7	BB _{Ai}	Baseband input A
8	$\overline{\text{BB}}_{\text{Ai}}$	Baseband input A inverse
9	BB _{Bi}	Baseband input B
10	$\overline{\text{BB}}_{\text{Bi}}$	Baseband input B inverse
12	LO _i	LO input
15, 16	Ph _{adj}	Phase adjustment (not necessary for regular applications)

3. Absolute Maximum Ratings

Parameters	Symbol	Value	Unit
Supply voltage	V_S	6	V
Input voltage	V_i	0 to V_S	V
Junction temperature	T_j	125	°C
Storage temperature range	T_{Stg}	-55 to +125	°C

4. Operating Range

Parameters	Symbol	Value	Unit
Supply voltage range	V_S	4.5 to 5.5	V
Ambient temperature range	T_{amb}	-40 to +85	°C

5. Thermal Resistance

Parameters	Symbol	Value	Unit
Junction ambient SO16	R_{thJA}	110	K/W

6. Electrical Characteristics

Test conditions (unless otherwise specified): $V_S = 5V$, $T_{amb} = 25^\circ C$, referred to test circuit, system impedance $Z_O = 50\Omega$, $f_{LO} = 900$ MHz, $P_{LO} = -10$ dBm, $V_{BBi} = 1$ V_{pp} differential.

No.	Parameters	Test Conditions	Pin	Symbol	Min.	Typ.	Max.	Unit	Type*
1.1	Supply voltage range		4, 5	V_S	4.5		5.5	V	A
1.2	Supply current		4, 5	I_S	24	30	37	mA	A
2	Baseband Inputs								
2.1	Input-voltage range (differential)		7-8, 9-10	V_{BBi}		1000	1500	mV _{pp}	D
2.2	Input impedance (single ended)			Z_{BBi}		3.2		k Ω	D
2.3	Input-frequency range ⁽⁵⁾			f_{BBi}	0		250	MHz	D
2.4	Internal bias voltage			V_{BBb}	2.35	2.5	2.65	V	A
2.5	Temperature coefficient			TC_{BB}		0.1	<1	mV/°C	D

*) Type means: A = 100% tested, B = 100% correlation tested, C = Characterized on samples, D = Design parameter

- Notes:
- The required LO level is a function of the LO frequency.
 - In reference to an RF output level ≤ -1 dBm and I/Q input level of 400 mV_{pp} differential.
 - Sideband suppression is tested without connection at pins 15 and 16. For higher requirements a potentiometer can be connected at these pins.
 - For $T_{amb} = -30^\circ C$ to $+85^\circ C$ and $V_S = 4.5V$ to $5.5V$.
 - By low impedance signal source.

6. Electrical Characteristics (Continued)

Test conditions (unless otherwise specified): $V_S = 5V$, $T_{amb} = 25^\circ C$, referred to test circuit, system impedance $Z_O = 50\Omega$, $f_{LO} = 900\text{ MHz}$, $P_{LO} = -10\text{ dBm}$, $V_{BBi} = 1\text{ V}_{pp}$ differential.

No.	Parameters	Test Conditions	Pin	Symbol	Min.	Typ.	Max.	Unit	Type*
3	LO Input								
3.1	Frequency range		12	f_{LOi}	50		1000	MHz	D
3.2	Input level ⁽¹⁾			P_{LOi}	-12	-10	-5	dBm	D
3.3	Input impedance			Z_{ILO}		50		Ω	D
3.4	Voltage standing wave ratio			$VSWR_{LO}$		1.4	2		D
3.5	Duty cycle range			DCR_{LO}	0.4		0.6		D
4	RF Output								
4.1	Output level		3	P_{RFo}	-5	-1	+2	dBm	B
4.2	LO suppression ⁽²⁾	$f_{LO} = 900\text{ MHz}$ $f_{LO} = 150\text{ MHz}$		LO_{RFo}	30 32	35 35		dB	B
4.3	Sideband suppression ^(2, 3)	$f_{LO} = 900\text{ MHz}$ $f_{LO} = 150\text{ MHz}$		SBS_{RFo}	35 30	40 35		dB	B
4.4	Phase error ⁽⁴⁾			P_e		<1		deg.	D
4.5	Amplitude error			A_e		< ±0.25		dB	D
4.6	Noise floor	$V_{BBi} = 2V$, $\bar{V}_{BBi} = 3V$ $V_{BBi} = \bar{V}_{BBi} = 2.5V$		N_{FL}		-132 -144		dBm/Hz	D
4.7	VSWR			$VSWR_{RF}$		1.6	2		D
4.8	3rd-order baseband harmonic suppression			S_{BBH}	35	45		dB	D
4.9	RF harmonic suppression			S_{RFH}		35		dB	D
5	Power-up Mode								
5.1	Supply current	$V_{PU} \leq 0.5V$ $V_{PU} = 1V$	4, 5	I_{PU}		10	1	μA	D
5.2	Settling time	$C_{SPU} = 100\text{ pF}$ $C_{LO} = 100\text{ pF}$ $C_{RFo} = 1\text{ nF}$	6 to 3	t_{sPU}		10		μs	D
6	Switching Voltage								
6.1	Power-on		1	V_{PUon}	4			V	D
6.2	Power-up		1	V_{PUdown}			1	V	D

*) Type means: A = 100% tested, B = 100% correlation tested, C = Characterized on samples, D = Design parameter

- Notes:
1. The required LO level is a function of the LO frequency.
 2. In reference to an RF output level $\leq -1\text{ dBm}$ and I/Q input level of 400 mV_{pp} differential.
 3. Sideband suppression is tested without connection at pins 15 and 16. For higher requirements a potentiometer can be connected at these pins.
 4. For $T_{amb} = -30^\circ C$ to $+85^\circ C$ and $V_S = 4.5V$ to $5.5V$.
 5. By low impedance signal source.

7. Diagrams

Figure 7-1. Typical Single Sideband Output Spectrum at $V_S = 4.5V$ and $V_S = 5.5V$, $f_{LO} = 900\text{ MHz}$, $P_{LO} = -10\text{ dBm}$, $V_{BBI} = 1\text{ V}_{PP}$ (differential) $T_{amb} = 25^\circ\text{C}$

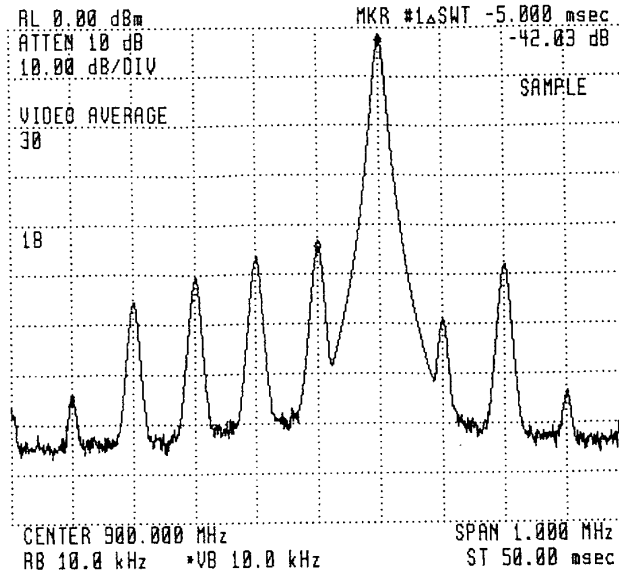

Figure 7-2. Typical GMSK Output Spectrum

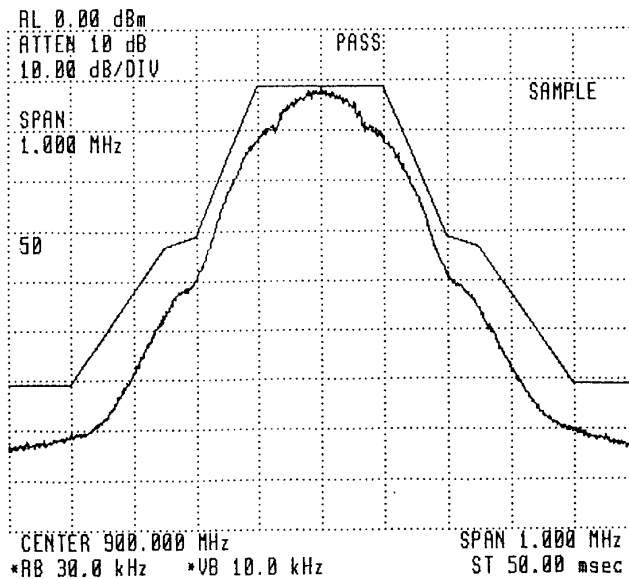

Figure 7-3. Demo Board Layout

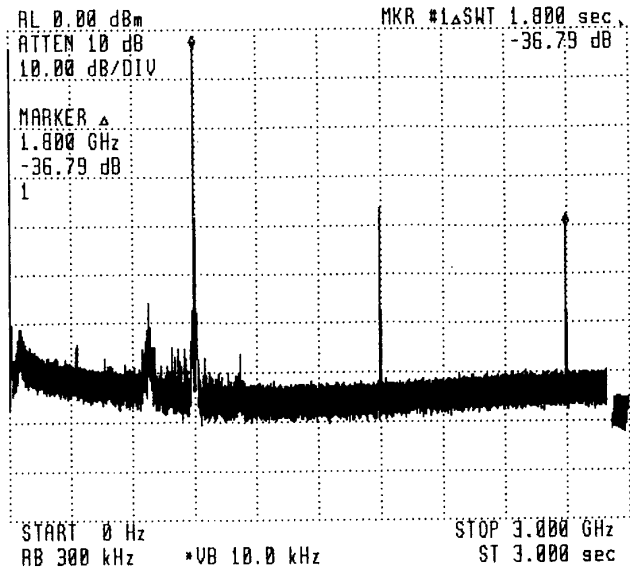

Figure 7-4. OIP3 versus T_{amb} , LO = 150 MHz, Level -20 dBm

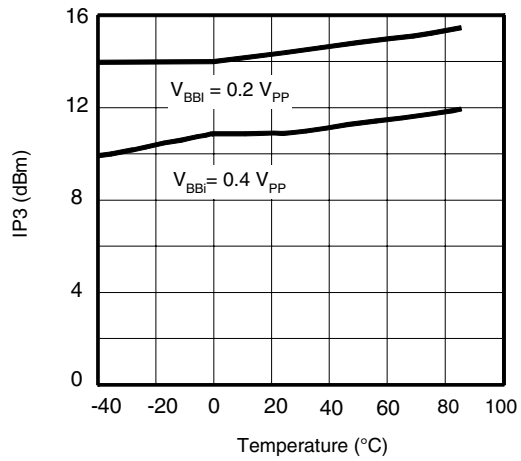

Figure 7-5. OIP3 versus T_{amb} , LO = 900 MHz, Level -10 dBm

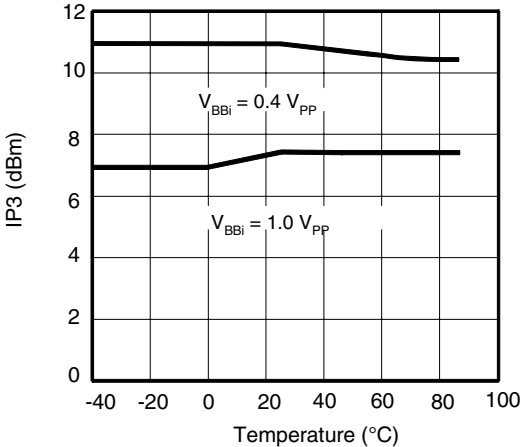

Figure 7-6. Output Power versus T_{amb}

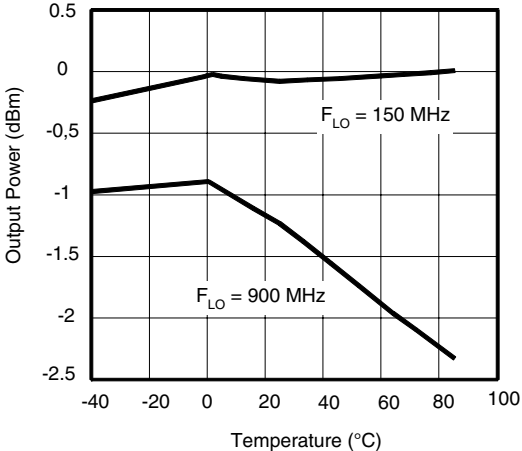

Figure 7-7. Supply Current versus T_{amb}

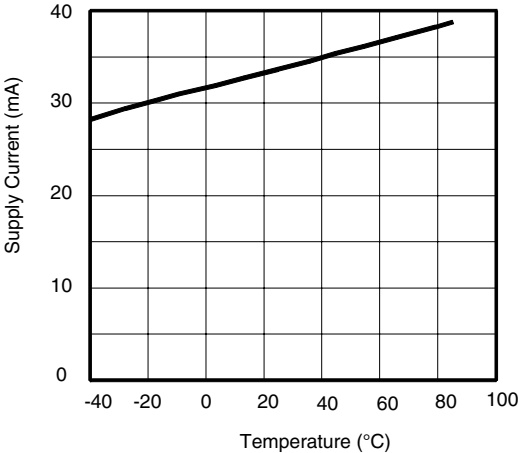

Figure 7-8. Typical S11 Frequency Response of the RF Output

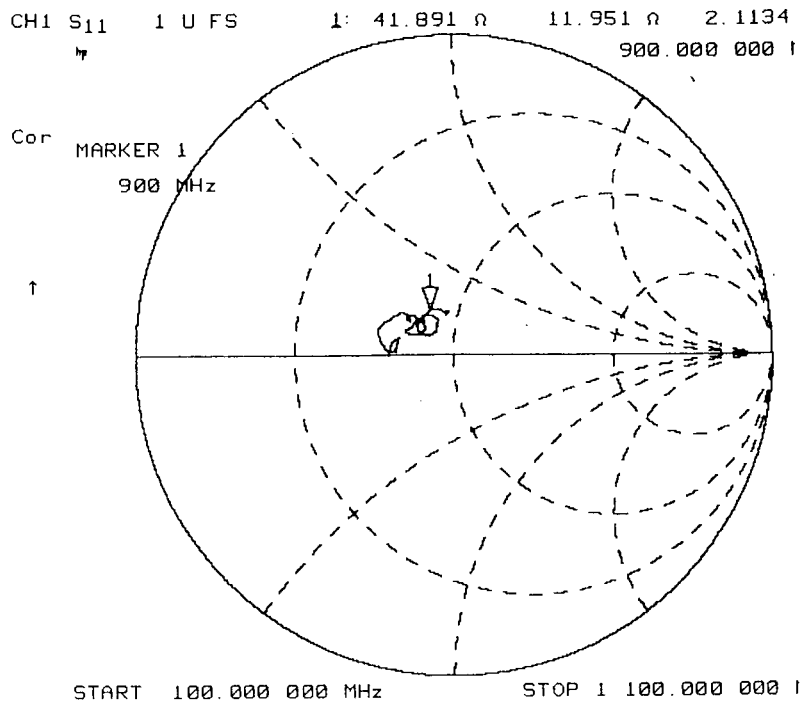

Figure 7-9. Typical VSWR Frequency Response of the RF Output

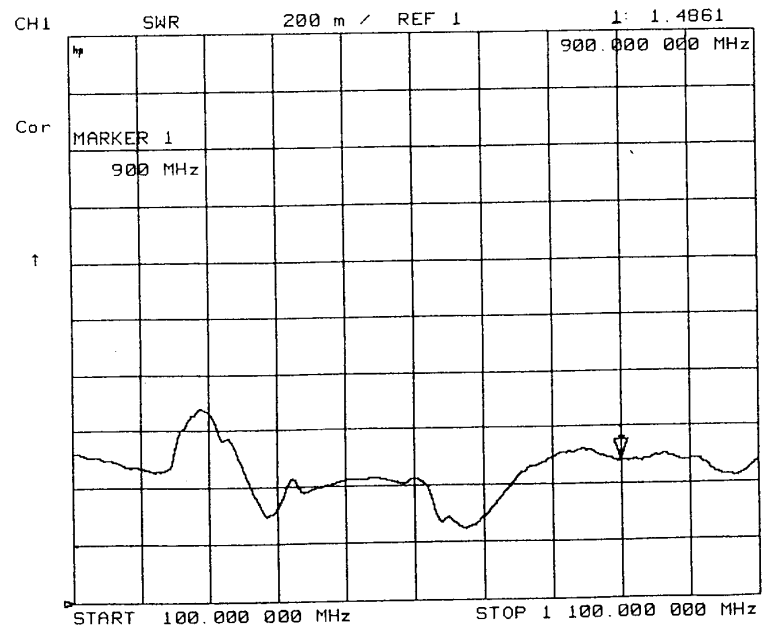

Figure 7-10. Typical S11 Frequency Response of the LO Input

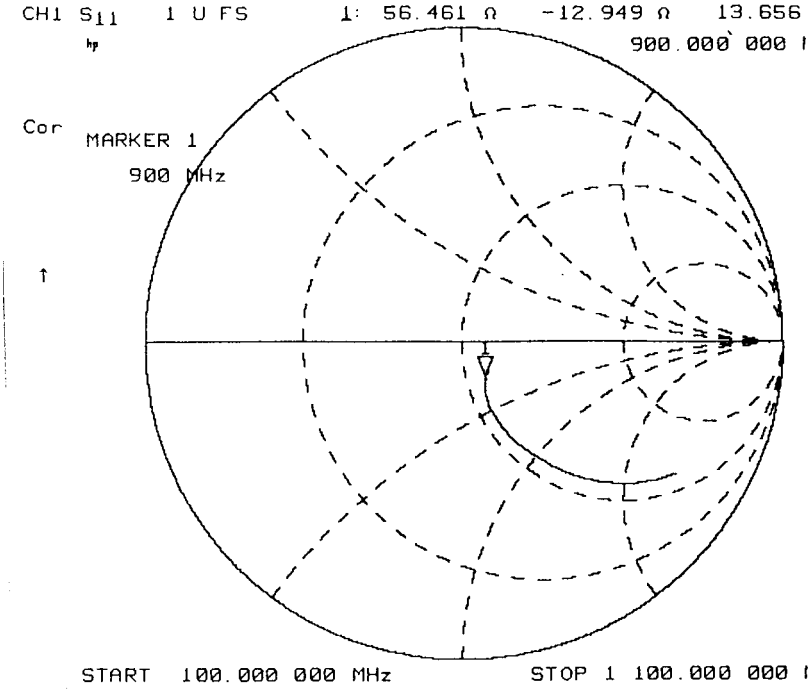

Figure 7-11. Typical VSWR Frequency Response of the LO input

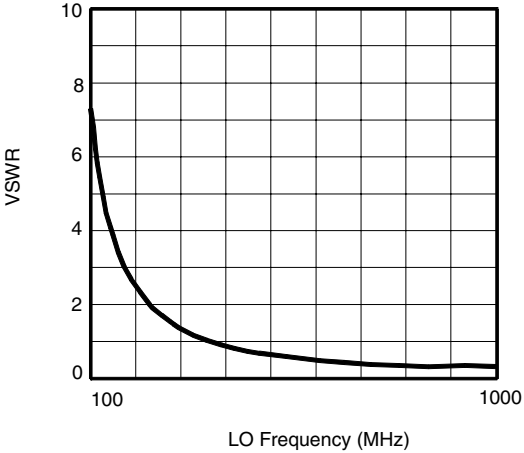

Figure 7-12. Typical Supply Current versus Temperature at $V_S = 5V$

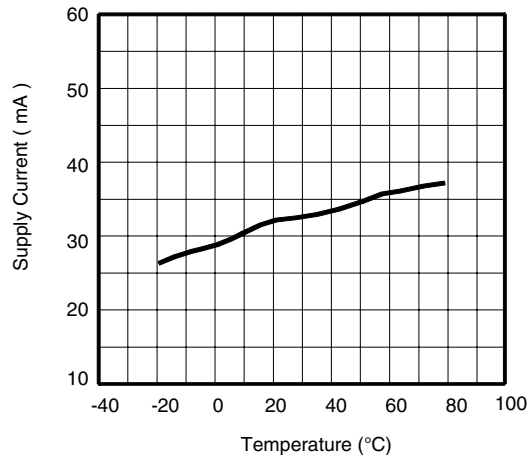

Figure 7-13. Typical Output Power versus LO-Frequency at $T_{amb} = 25^\circ C$, $V_{BBI} = 230\text{ mV}_{PP}$ (differential)

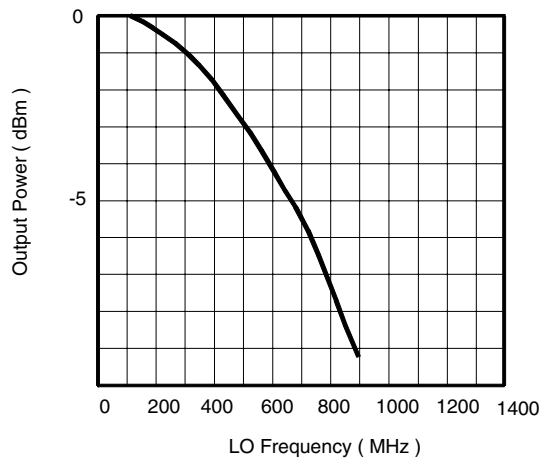

Figure 7-14. Typical required V_{BBI} Input Signal (differential) versus LO Frequency for $P_O = 0\text{ dBm}$ and $P_{O} = -2\text{ dBm}$

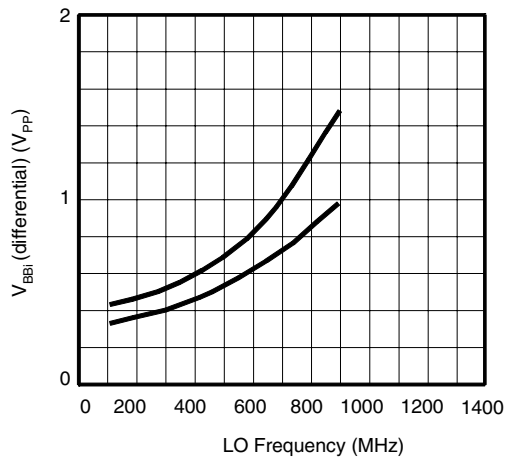

Figure 7-15. Typical useful LO Power Range versus LO Frequency at $T_{amb} = 25^{\circ}C$

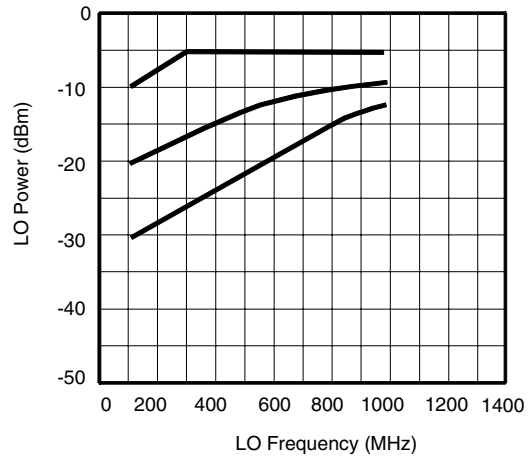

Figure 7-16. Application Circuit

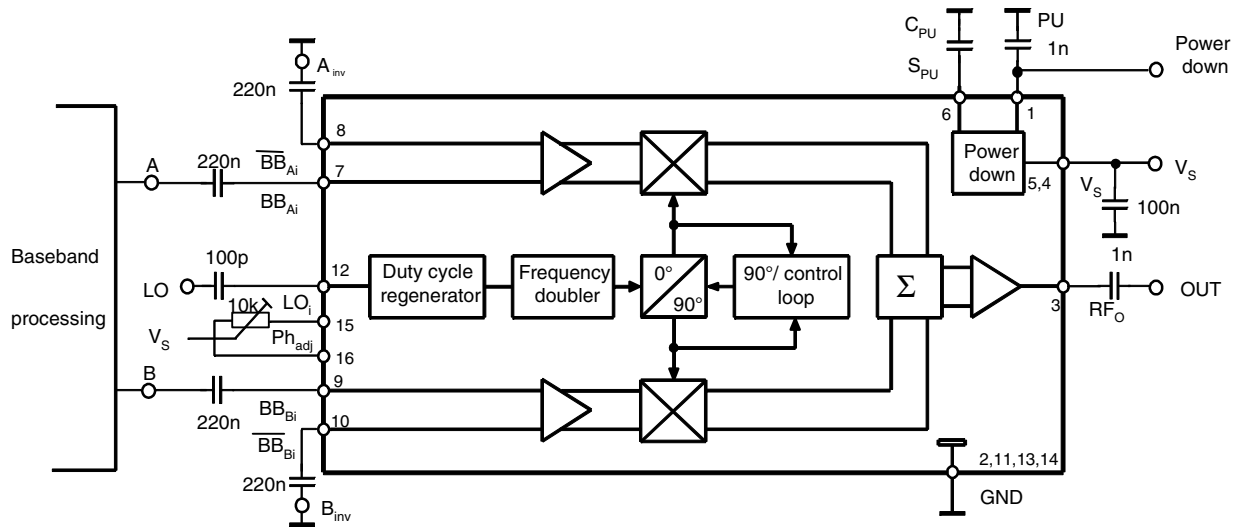
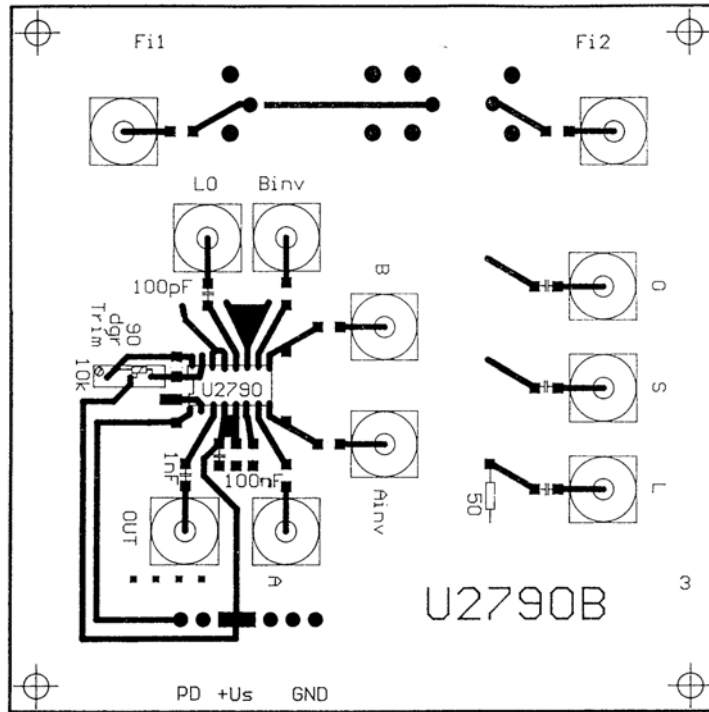

Figure 7-17. Demo Board Layout



8. Application Notes

8.1 Noise Floor and Settling Time

In order to reduce noise on the power-up control input and improve the wide-off noise floor of the 900-MHz RF output signal, capacitor C_{PU} should be connected from pin 6 to ground in the shortest possible way.

The settling time has to be considered for the system under design. For GSM applications, a value of $C_{PU} = 1 \text{ nF}$ defines a settling time, t_{sPU} , equal or less than 3 ms. This capacitance does not have any influence on the noise floor within the relevant GSM mask. For mobile applications the mask requirements can be achieved very easily without C_{PU} .

A significant improvement of the wide-off noise floor is obtainable with C_{PU} greater than 100 nF. Such values are recommended for applications where the settling time is not critical such as in base stations. Coupling capacitors for LO_i and RF_o also have a certain impact on the settling time. The values used for the measurements are $C_{LO_i} = 100 \text{ pF}$ and $C_{RF_o} = 1 \text{ nF}$.

8.2 Baseband Coupling

The U2790B-FP (SO16) has an integrated biasing network which allows AC coupling of the baseband signal at a low count of external components. The bias voltage is $2.5V \pm 0.15V$.

Figure 7-17 shows the baseband input circuitry with a resistance of $3.2 \text{ k}\Omega$ for each asymmetric input. The internal DC offset between A and A, and B and B is typically $< \pm 1 \text{ mV}$ with a maximum of $\pm 3 \text{ mV}$. DC coupling is also possible with an external DC voltage of $2.5 \pm 0.15V$.

Figure 8-1. Baseband Input Circuitry

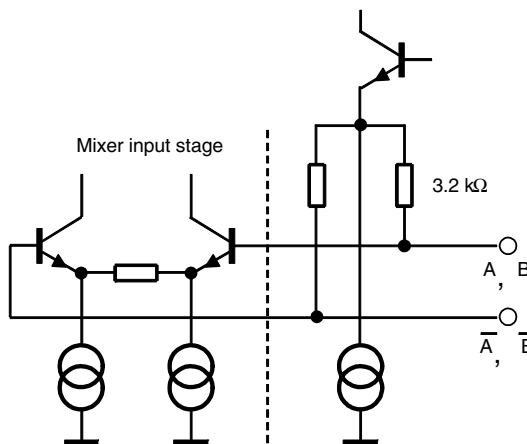

RF Output Circuitry LO Input Circuitry

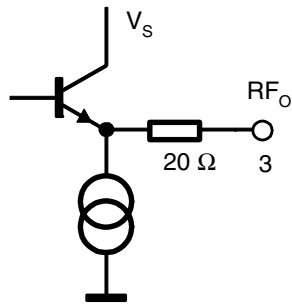
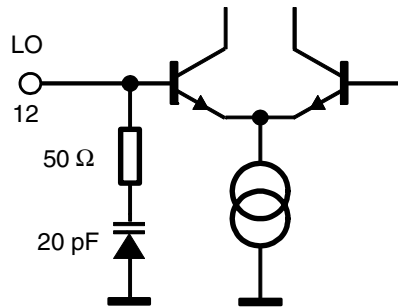

Figure 8-2. LO Input Circuitry



9. Ordering Information

Extended Type Number	Package	Remarks
U2790B-NFPH	SO16	Tube, Pb-free
U2790B-NFPG3H	SO16	Taped and reeled, Pb-free

10. Package Information

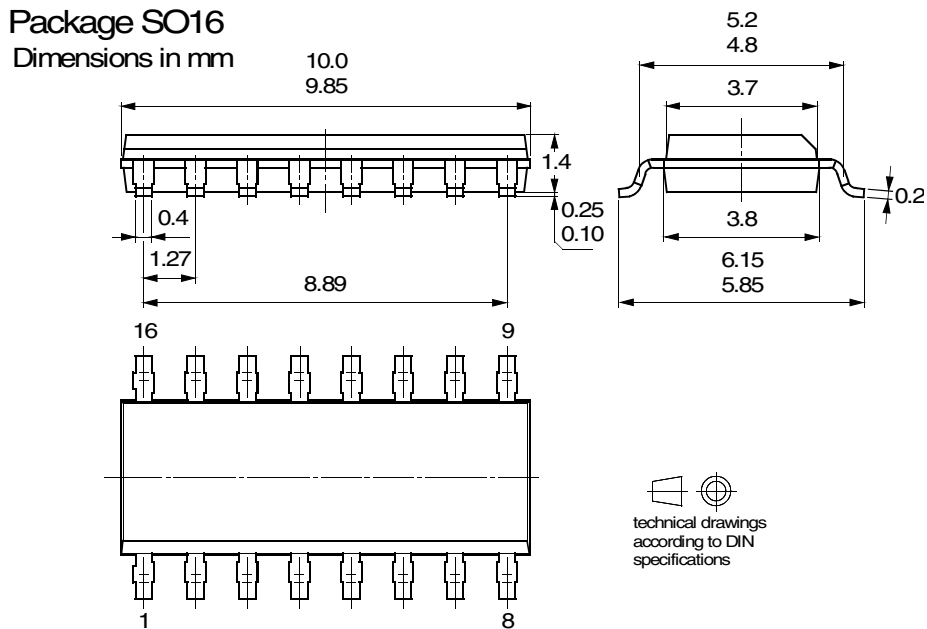

11. Revision History

Please note that the following page numbers referred to in this section refer to the specific revision mentioned, not to this document.

Revision No.	History
4583D-CELL-07/06	<ul style="list-style-type: none"> • Page 3, Abs. Max.Ratings table: Storage temperature values changed • Page 2, Pin Description table: symbol of Pins 8 and 10 changed • Put datasheet in a new template



Atmel Corporation

2325 Orchard Parkway
San Jose, CA 95131, USA
Tel: 1(408) 441-0311
Fax: 1(408) 487-2600

Regional Headquarters

Europe

Atmel Sarl
Route des Arsenaux 41
Case Postale 80
CH-1705 Fribourg
Switzerland
Tel: (41) 26-426-5555
Fax: (41) 26-426-5500

Asia

Room 1219
Chinachem Golden Plaza
77 Mody Road Tsimshatsui
East Kowloon
Hong Kong
Tel: (852) 2721-9778
Fax: (852) 2722-1369

Japan

9F, Tonetsu Shinkawa Bldg.
1-24-8 Shinkawa
Chuo-ku, Tokyo 104-0033
Japan
Tel: (81) 3-3523-3551
Fax: (81) 3-3523-7581

Atmel Operations

Memory

2325 Orchard Parkway
San Jose, CA 95131, USA
Tel: 1(408) 441-0311
Fax: 1(408) 436-4314

Microcontrollers

2325 Orchard Parkway
San Jose, CA 95131, USA
Tel: 1(408) 441-0311
Fax: 1(408) 436-4314

La Chantrerie
BP 70602
44306 Nantes Cedex 3, France
Tel: (33) 2-40-18-18-18
Fax: (33) 2-40-18-19-60

ASIC/ASSP/Smart Cards

Zone Industrielle
13106 Rousset Cedex, France
Tel: (33) 4-42-53-60-00
Fax: (33) 4-42-53-60-01

1150 East Cheyenne Mtn. Blvd.
Colorado Springs, CO 80906, USA
Tel: 1(719) 576-3300
Fax: 1(719) 540-1759

Scottish Enterprise Technology Park
Maxwell Building
East Kilbride G75 0QR, Scotland
Tel: (44) 1355-803-000
Fax: (44) 1355-242-743

RF/Automotive

Theresienstrasse 2
Postfach 3535
74025 Heilbronn, Germany
Tel: (49) 71-31-67-0
Fax: (49) 71-31-67-2340

1150 East Cheyenne Mtn. Blvd.
Colorado Springs, CO 80906, USA
Tel: 1(719) 576-3300
Fax: 1(719) 540-1759

Biometrics/Imaging/Hi-Rel MPU/ High-Speed Converters/RF Datacom

Avenue de Rochepleine
BP 123
38521 Saint-Egreve Cedex, France
Tel: (33) 4-76-58-30-00
Fax: (33) 4-76-58-34-80

Literature Requests

www.atmel.com/literature

Disclaimer: The information in this document is provided in connection with Atmel products. No license, express or implied, by estoppel or otherwise, to any intellectual property right is granted by this document or in connection with the sale of Atmel products. **EXCEPT AS SET FORTH IN ATMEL'S TERMS AND CONDITIONS OF SALE LOCATED ON ATMEL'S WEB SITE, ATMEL ASSUMES NO LIABILITY WHATSOEVER AND DISCLAIMS ANY EXPRESS, IMPLIED OR STATUTORY WARRANTY RELATING TO ITS PRODUCTS INCLUDING, BUT NOT LIMITED TO, THE IMPLIED WARRANTY OF MERCHANTABILITY, FITNESS FOR A PARTICULAR PURPOSE, OR NON-INFRINGEMENT. IN NO EVENT SHALL ATMEL BE LIABLE FOR ANY DIRECT, INDIRECT, CONSEQUENTIAL, PUNITIVE, SPECIAL OR INCIDENTAL DAMAGES (INCLUDING, WITHOUT LIMITATION, DAMAGES FOR LOSS OF PROFITS, BUSINESS INTERRUPTION, OR LOSS OF INFORMATION) ARISING OUT OF THE USE OR INABILITY TO USE THIS DOCUMENT, EVEN IF ATMEL HAS BEEN ADVISED OF THE POSSIBILITY OF SUCH DAMAGES.** Atmel makes no representations or warranties with respect to the accuracy or completeness of the contents of this document and reserves the right to make changes to specifications and product descriptions at any time without notice. Atmel does not make any commitment to update the information contained herein. Unless specifically provided otherwise, Atmel products are not suitable for, and shall not be used in, automotive applications. Atmel's products are not intended, authorized, or warranted for use as components in applications intended to support or sustain life.

© 2006 Atmel Corporation. All rights reserved. Atmel®, logo and combinations thereof, Everywhere You Are® and others are registered trademarks or trademarks of Atmel Corporation or its subsidiaries. Other terms and product names may be trademarks of others.